



Comm Fabric: Transformation, Resiliency and Agility

Tim Maguire



Communication Fabric

We are responsible for the fabric and underlying network that connects our customers to our employees, services and applications. Our portfolio at a glance:



Communication Fabric

The network linking our on-prem systems to public cloud providers. We design and support Silk, the evolution of our highly resilient SIP network responsible for all of Liberty Mutual telephony.



Cloud Networking

Our team of Infrastructure Engineers has greatly improved the supportability and operations of our cloud networks using Infrastructure as Code for Google Cloud Platform and Azure VNETs in regions around the globe.

Connecting Liberty Mutual to our customers and Partners

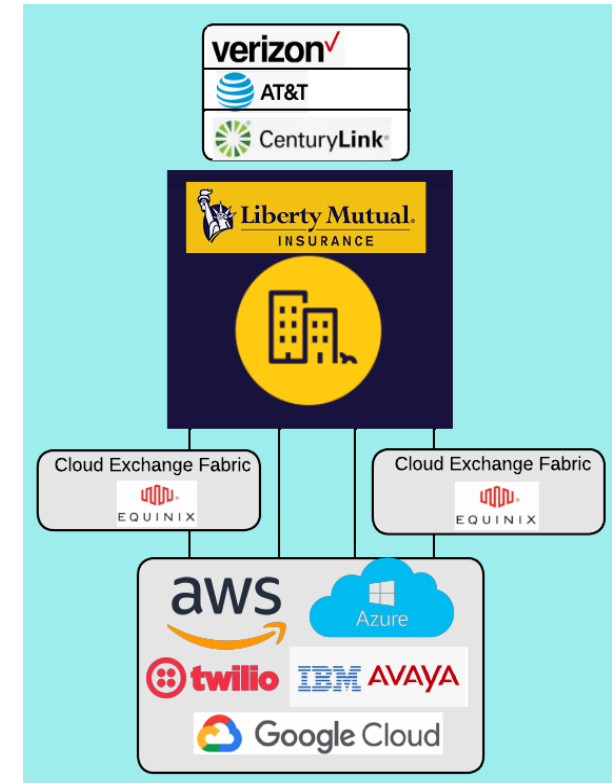

Communication Fabric

World-class VoIP resiliency with three data center redundancy



350K calls per day

Expanding transparency by providing self-service tools for visibility with alerting



4.343 score
top call quality

Improved deployment and operational practices



Real-time alerts and incident creation

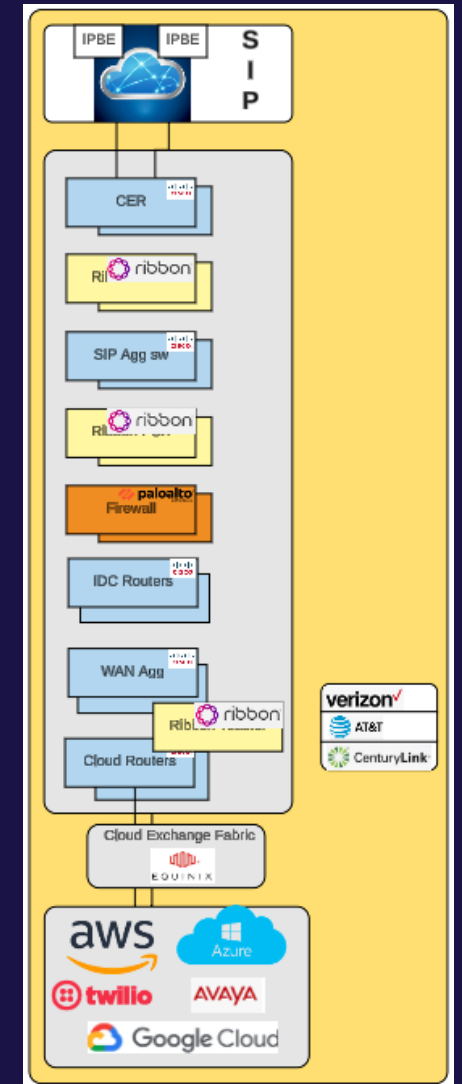

Communication Fabric Interconnect Monitoring

Sources of Data

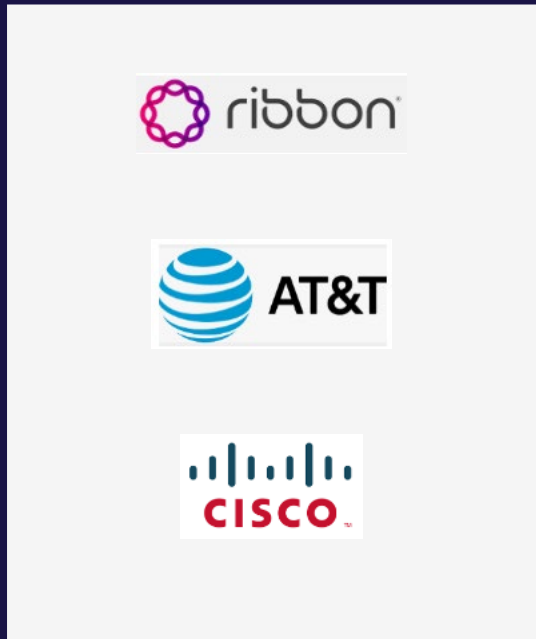

Tools used to build monitoring platform



Power Automate



Amazon API Gateway

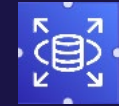

RDS Storage & Audit



AWS Lambda



AWS CloudWatch



Azure AD Identity Protection



Communication Fabric

Alarm for MOS Threshold with alerting

Call Data Record monitoring and automated validation

Call Volume threshold with alerting

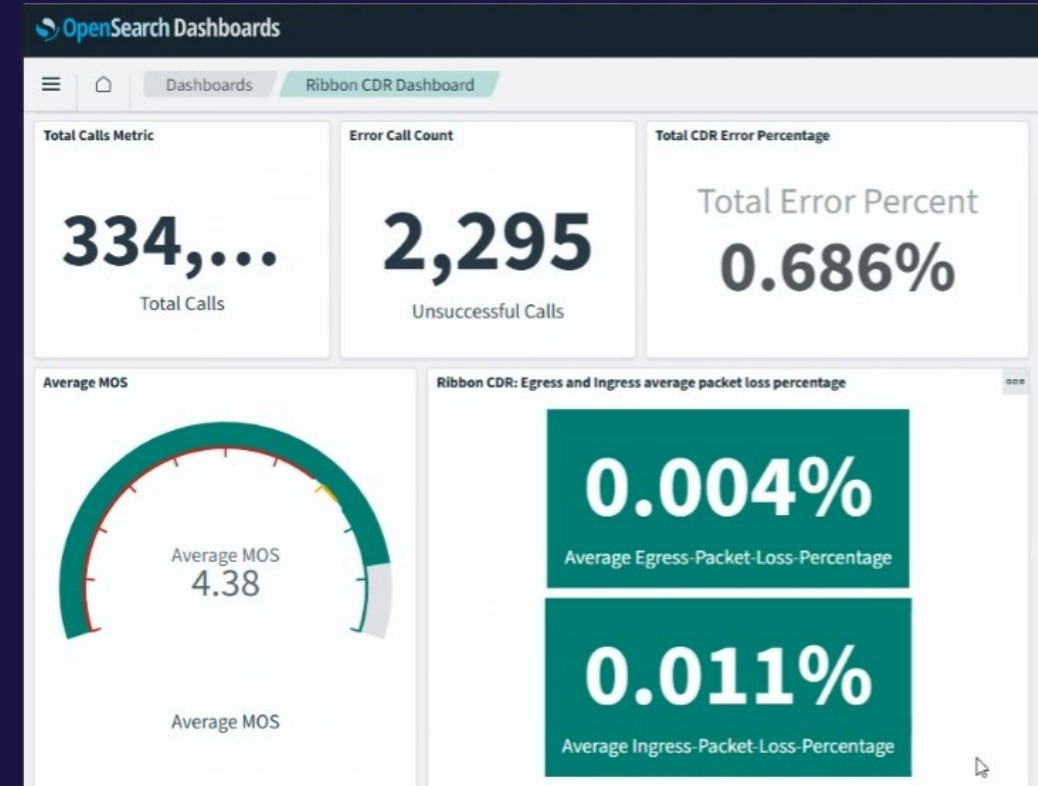

```
NOT Sonus-Call-Disconnect-Reason-Field.keyword: CPC_NO_PSX_ROUTES - NUMBER FOUND BUT NOT ACTIVE IN TDW X
```



Accelerate business delivery in telephony services

We are building self-service capabilities for our telecom responsibilities, making Global Network Communications a world-class destination for these offerings.

Simplified number management



145K individual phone numbers

Cloud enabled inventory platforms



17K Toll Free Numbers

Business Outcomes: *Simplify and expedite telecom service delivery via self-service tools and orchestration of our platforms*

Partnering to grow our business:
Volvo toll-free number 800-317-3698 for customer service or to get a quote.



Portsmouth, NH Insurance Office | Liberty Mutual Insurance

[Website](#) [Directions](#) [Save](#) [Call](#)

3.0 ★★★★★ 8 Google reviews

Insurance agency in Portsmouth, New Hampshire

Address: Attn: Personal Sales, 225 Borthwick Ave, 1 South St, Portsmouth, NH 03801

Hours: Open · Closes 5PM ▾

Phone: (603) 431-3350



Telephony Data Warehouse

We utilize our TDW as the entry and authorization point for any client wanting to interact with the PSX

Telephony Data Warehouse

DID INDEX DID PAL ATT SPP INDEX TFN INDEX PSX

DID Index

| Actions | AssignedOfficeNum | Number | Status | Purpose | OfficeLocation | OfficeCountry | Employ |
|---------|----------------------|----------------------|----------------------|-----------------------------|----------------------|----------------------|----------------------|
| | <input type="text"/> | <input type="text"/> | <input type="text"/> | <input type="text"/> | <input type="text"/> | <input type="text"/> | <input type="text"/> |
| | 0325 | 2012211438 | Retired | Employee Direct Dial Number | Saddle Brook, NJ | US | |
| | 0325 | 2012211439 | Active | Employee Direct Dial Number | Saddle Brook, NJ | US | n15411 |
| | 0325 | 2012211440 | Active | Employee Direct Dial Number | Saddle Brook, NJ | US | n02922 |
| | 0325 | 2012211441 | Available | Employee Direct Dial Number | Saddle Brook, NJ | US | |
| | | | Active | Employee Direct Dial Number | Saddle Brook, NJ | US | n01110 |
| | | | Available | Employee Direct Dial Number | Saddle Brook, NJ | US | |
| | | | Available | Employee Direct Dial Number | Saddle Brook, NJ | US | |
| | | | Active | Employee | | | 02162 |
| | | | Active | Employee | | | 01897 |

Number of Requests per Endpoint



Type of API Request



3500 PSX API Calls per month



Communication Fabric

Simplify and expedite network and telecom service delivery via self-service tools and orchestration of our platforms

Leverage best in class partners and suppliers with API enabled infrastructure for simplified on-boarding of cloud services with low switching costs



From



To

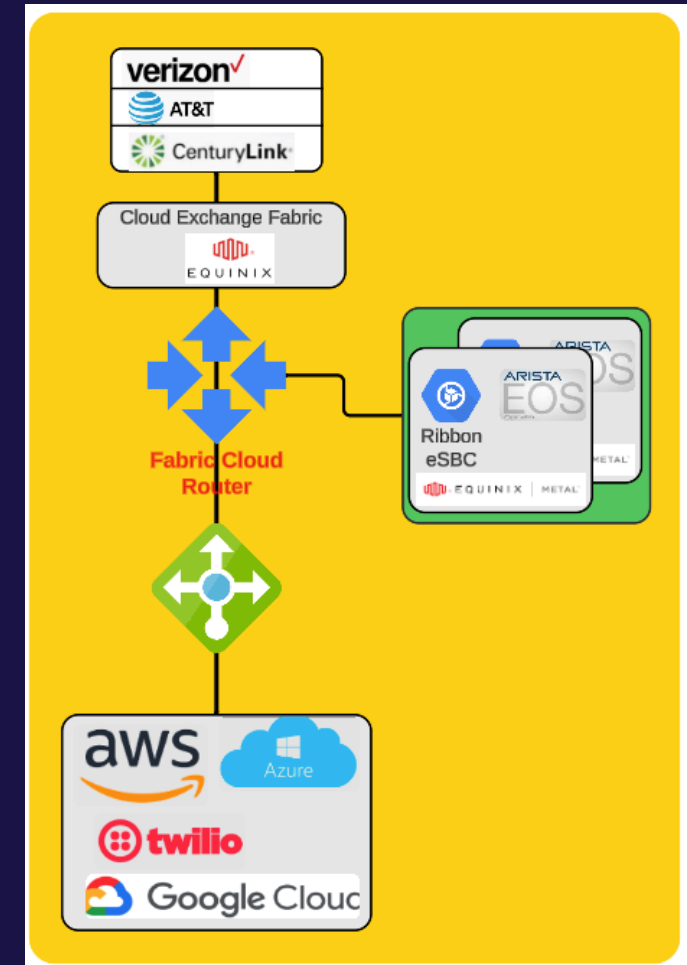

Contracts, lead-times, installation costs

Self-service, pay for use, API driven





Liberty Mutual[®]

INSURANCE